

# On-farm conservation and participatory maize breeding in Portugal; lessons learnt and future perspectives

Pedro Mendes-Moreira  
Maria Carlota Vaz Patto  
João Mendes Moreira  
Arnel Hallauer  
Silas Pêgo

Escola Superior Agrária de Coimbra,  
Departamento de Ciências Agronómicas





# Maize introduction in Portugal

## Hallauer (1994) proposed distinct four stages for maize breeding

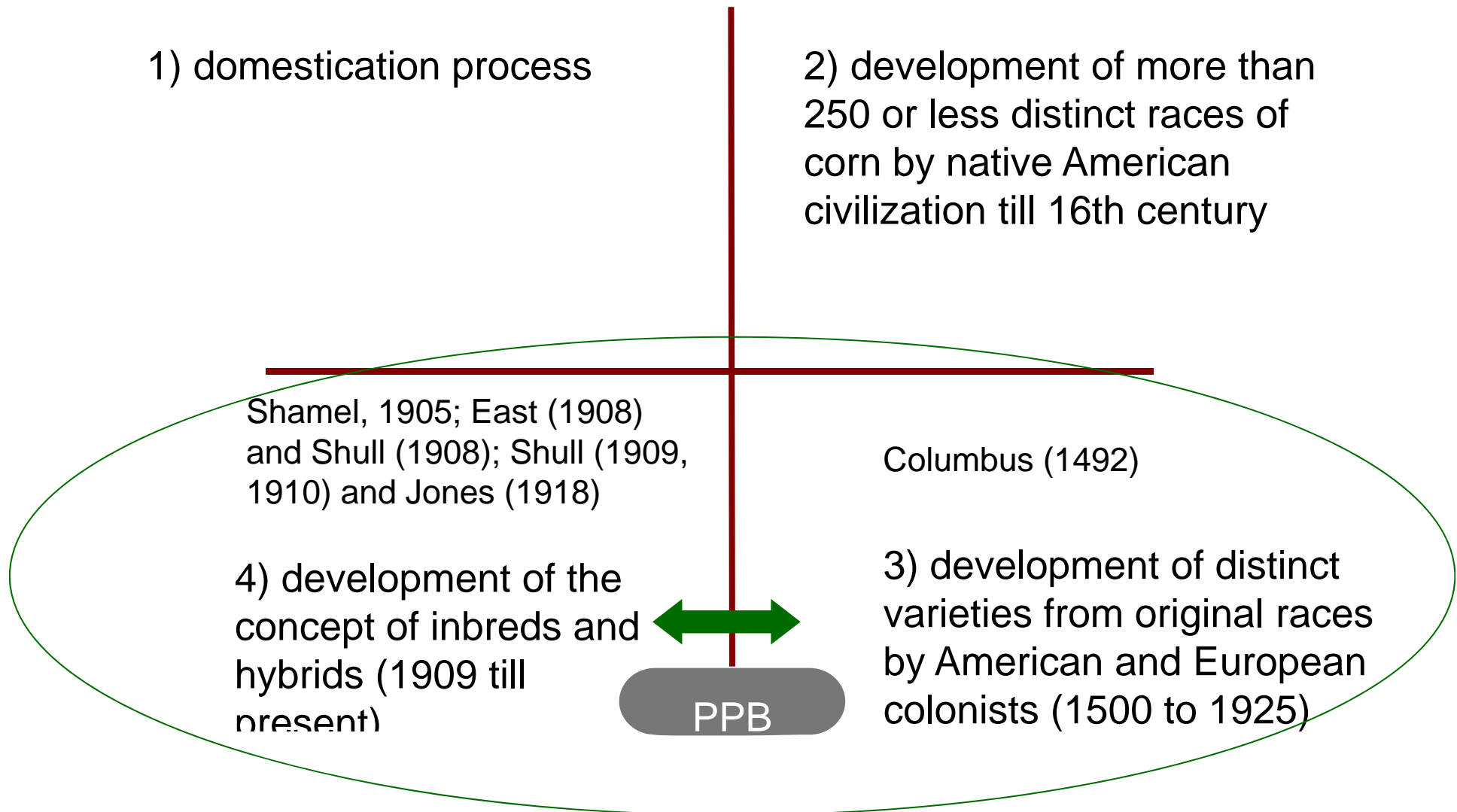

Landraces are not only seeds, plants...genes



# Stage three (more than 500 years relationship)



They have...



Silas Pego

They have strong links with human traditions



Silas Pego



... and empirical knowledge.



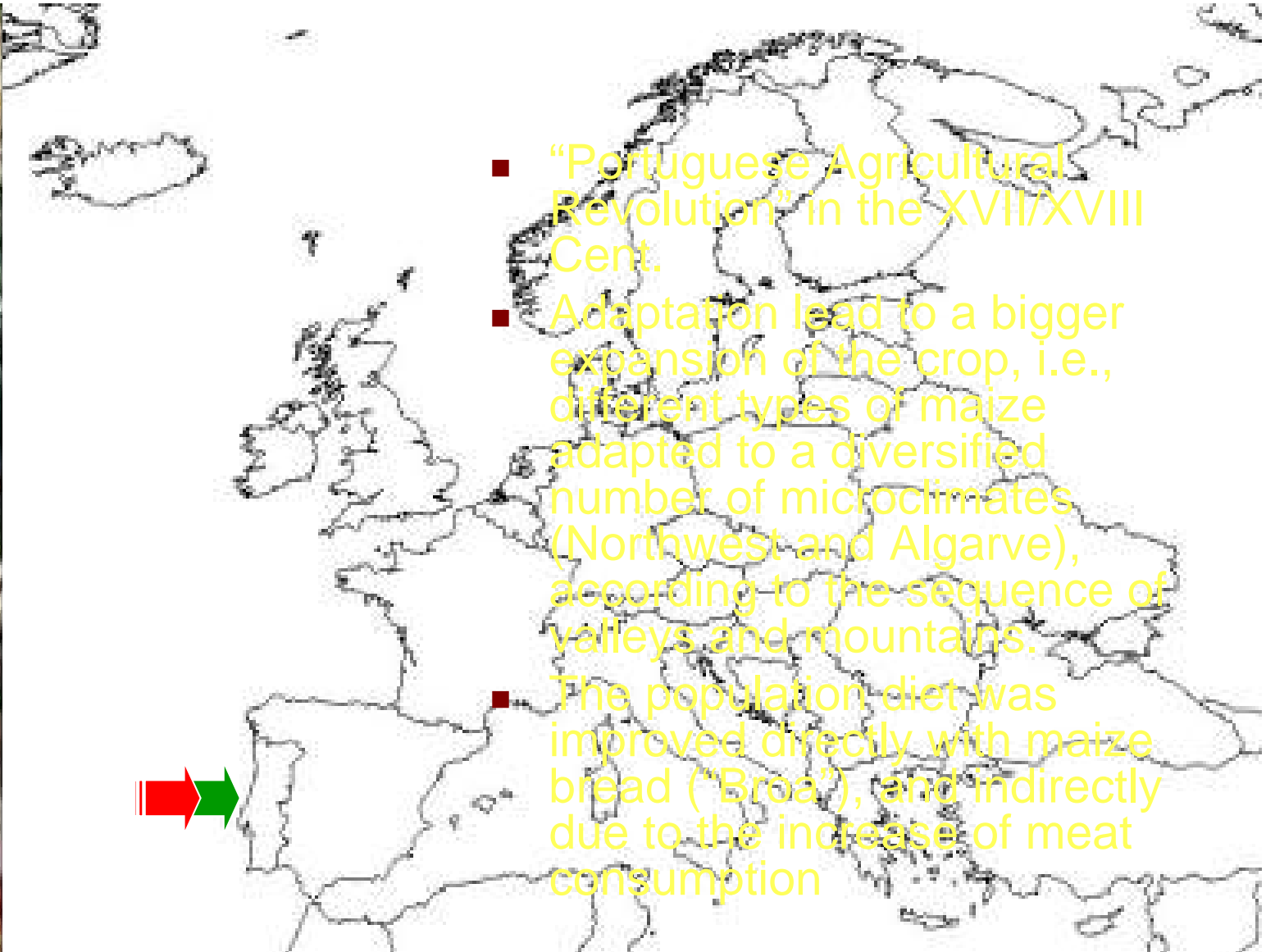

- “Portuguese Agricultural Revolution” in the XVII/XVIII Cent.
- Adaptation lead to a bigger expansion of the crop, i.e., different types of maize adapted to a diversified number of microclimates (Northwest and Algarve), according to the sequence of valleys and mountains.
- The population diet was improved directly with maize bread (“Broa”), and indirectly due to the increase of meat consumption



## Stage 4 (less than 75 years)

- After 2nd World War, American success in maize breeding had a tremendous impact in Europe due to the new hybrid seeds then available
- Portugal was one of the first countries where American hybrids were introduced
- The FAO programmes for hybrid production in Europe had excellent adaptation to Portugal
- Breeding stations were established along the country, from North to South: **Braga**, Porto, Viseu, Elvas and Tavira

Adaptation do Portugal conditions  
*versus* adaptation to Portuguese  
farmers needs

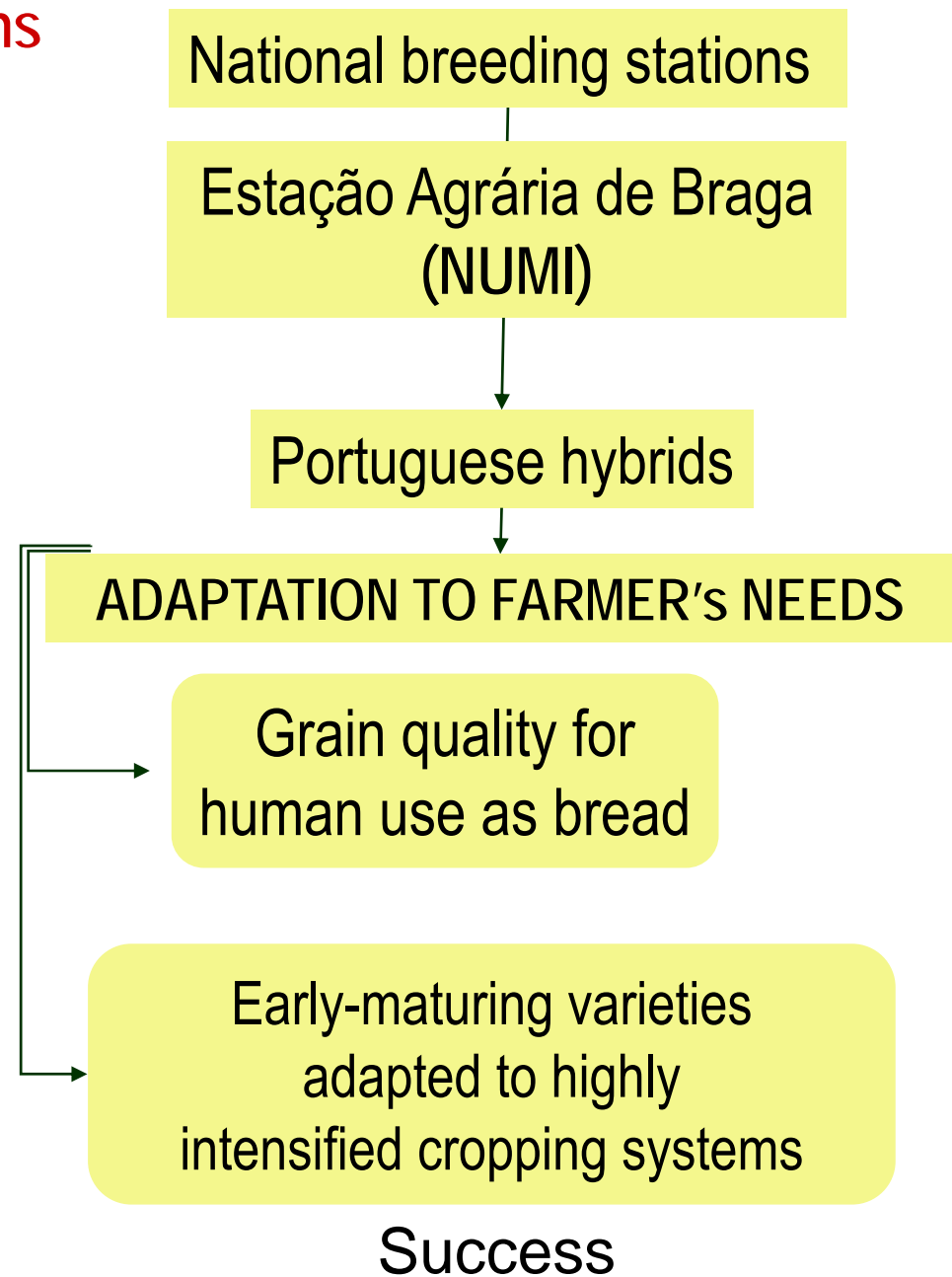
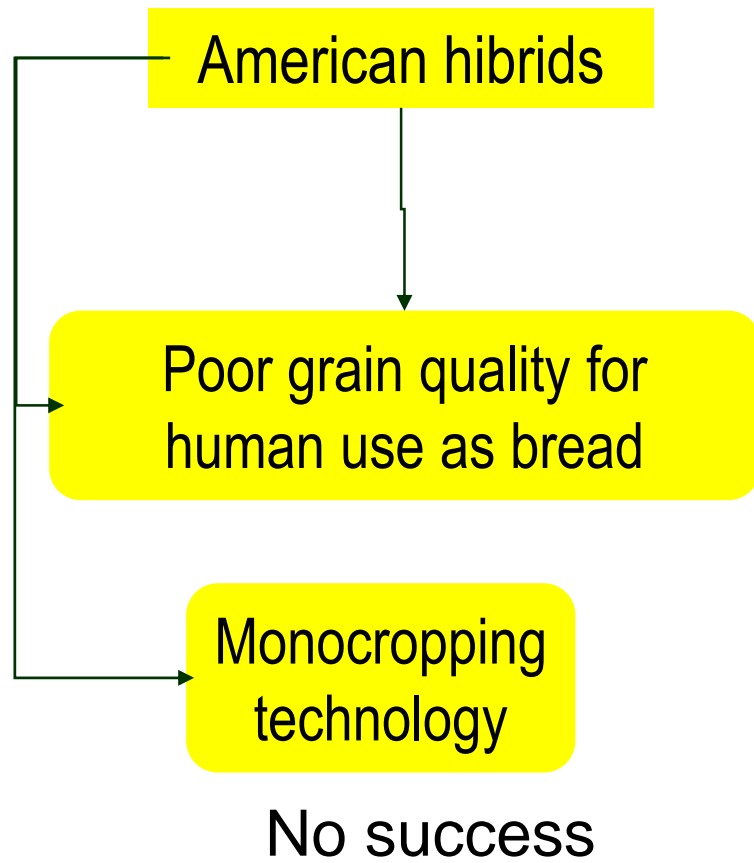



Silas Pêgo

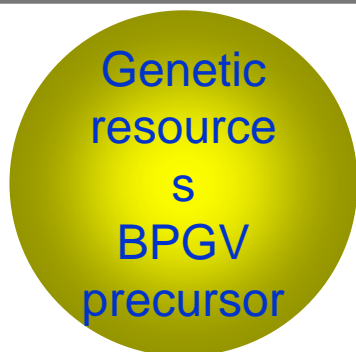

**1975-76 maize first collection missions**  
Emma Bennet (FAO)  
**Finance 1st cold storages**  
precursor of BPGV



**VASO-Project since 1984**  
Dr. Wayne Haag (as **CIMMYT** director for maize breeding in the Mediterranean area)  
Finance de project since 1985.  
Pre-breeding work (several improved landraces)



HB 13  
HB 19



# Participatory Maize Breeding (Breeding on-farm)

# VASO Project



2005 10 4

# Integrant Philosophy



# Productivist Philosophy

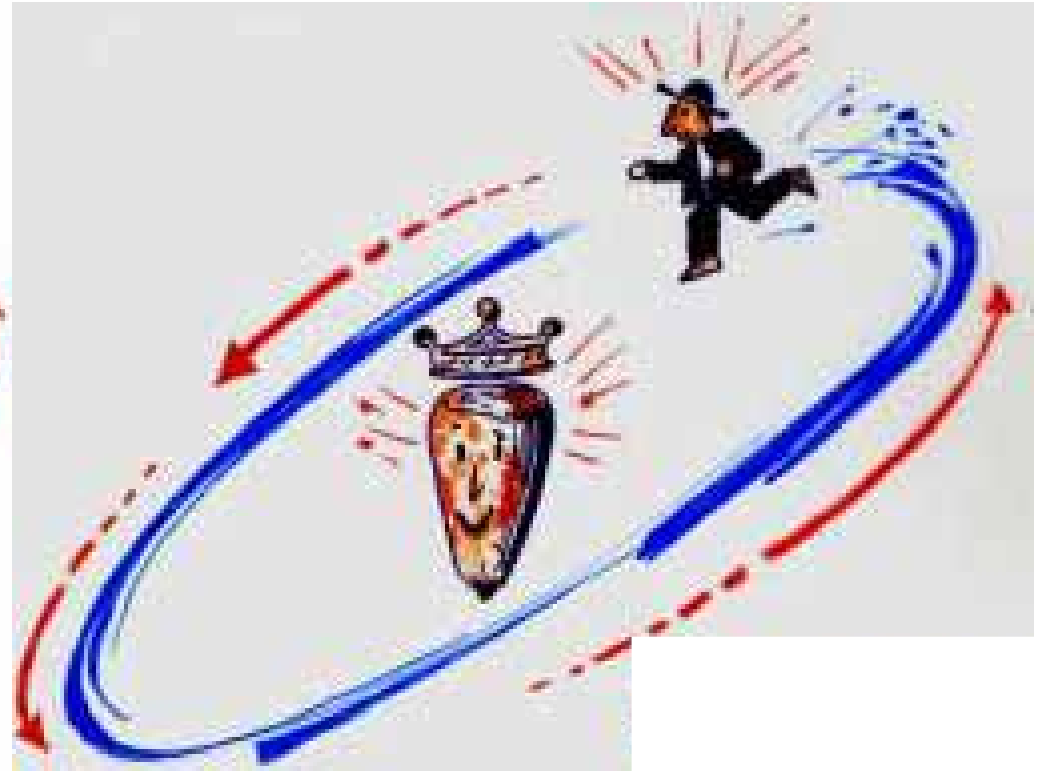

(Pêgo, 1997)

Pego, S. & Antunes, M.P. (1997). Resistance or tolerance? Philosophy, may be the answer. *Proceedings of the XIX – Conference of the International Working Group on Ostrinia*. Guimarães Portuga

## The main question

- “How to solve the problem of the small Portuguese farmers where the land is scarce and the high demographic density exists”

*i.e.*

- where the American model do not fit and where the multinationals do not have market to operate?

# VASO Project

Important decisions  
for project success

Location

**traditional maize area**

**Agro/sociologic/economics data availability**

Support of a local elite farmers' association (CGAVS)

Test the efficiency of an alternative project supposed to improve the local germplasm in order to be competitive, at least in certain specific circumstances, side by side with the local hybrids production

Germplasm

1 -Local Germplasm  
(e.g. 'Pigarro',  
'Amiúdo')

2 -Exotic germplasm  
'FANDANGO'

Farmer

The right people to work with,

Work side by side with the farmer, to whom the decision power will be allowed

Their initial acceptance and enthusiasm

# Sousa Valley

Lousada

Paredes

Paços de Ferreira

Felgueiras

Penafiel





# Aims



- The evaluation of the yield gain and plant performance after 20 years of a participatory plant breeding approach.
  - ◆ **‘Pigarro’**: two breeding methodologies
  - ◆ **‘Fandango’**: different cycles of mass selection initiated by the breeder and continued by the farmer
- Based on the collected data we have search what were the best explanatory variables for yield.



# Genetic Resources Material and Methods



# 'Pigarro' Selection

# VASO Project (breeding methodologies)

## Pigarro Mass Selection 1984-2009...

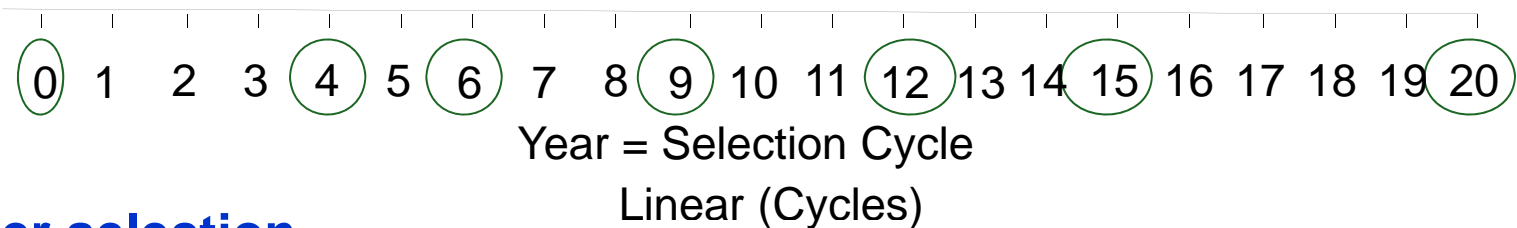

**Farmer selection**  
(A-B-C selection process)

## Pigarro Recurrent Selection (S2) 1984-1998

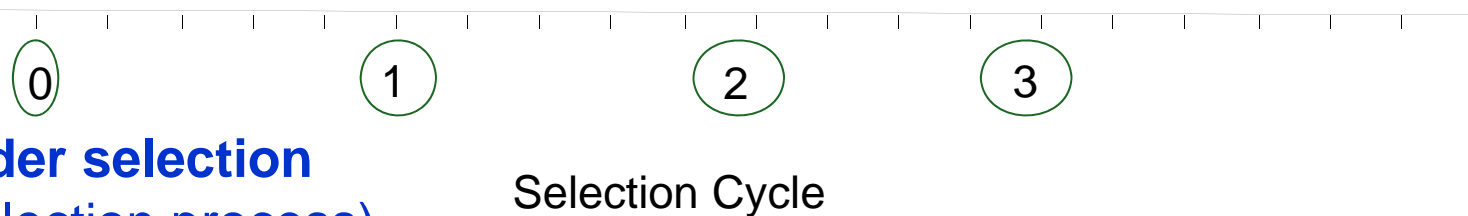

**Breeder selection**  
(S2 selection process)

# Population $C_0$ (Selection by $S_2$ lines) PIGARRO

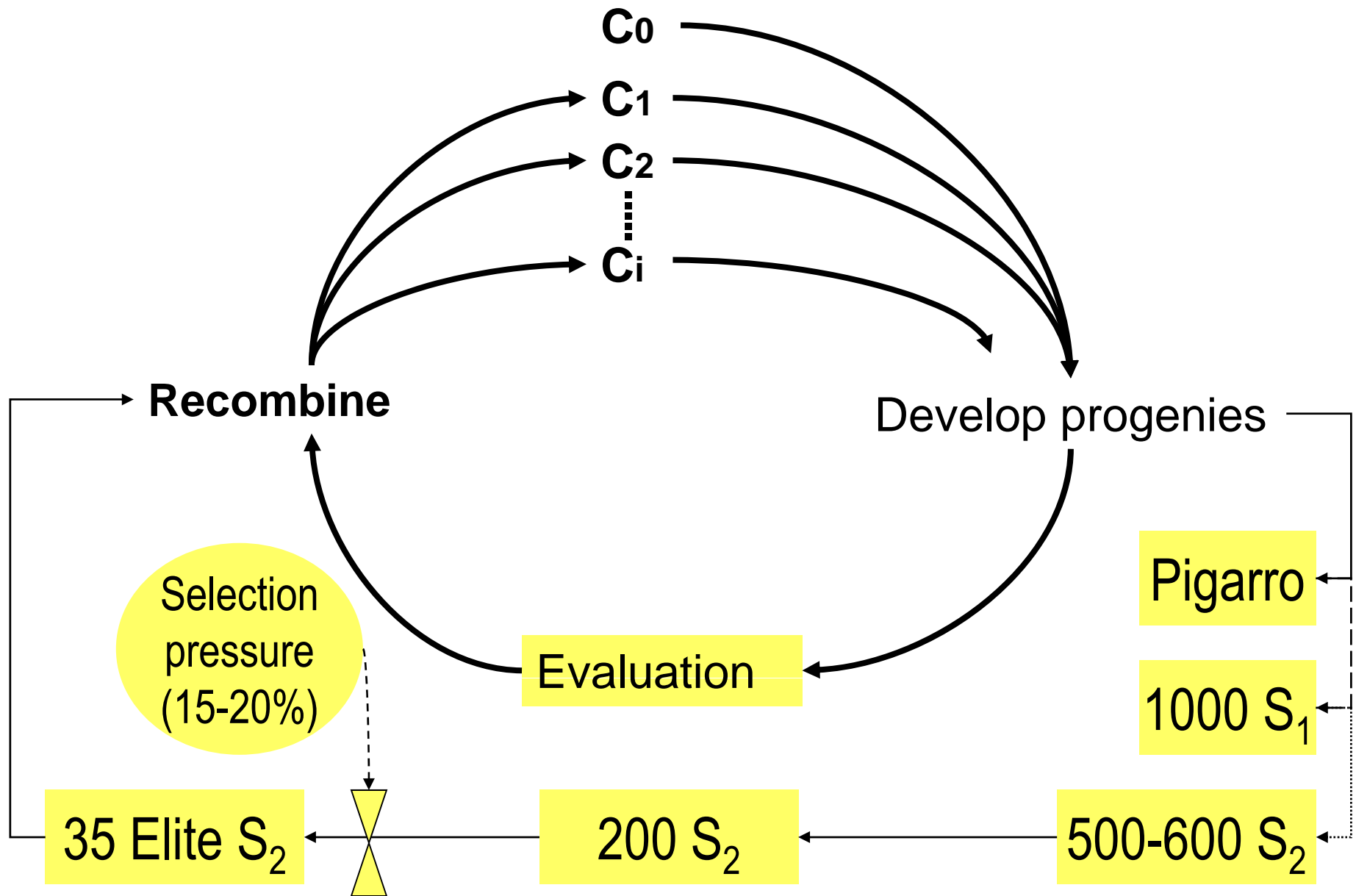

# The ABC of phenotypic recurrent selection

Two parental control mass selection:

in the field

before pollen shedding

(male flowers-detasseling, undesirable plants, weakest, disease and pest susceptible)

before harvesting (ear size, root and stalk quality, pest and disease tolerance, prolificity)

at the storing facilities

after harvesting (ear length, kernel row number, damage ears)



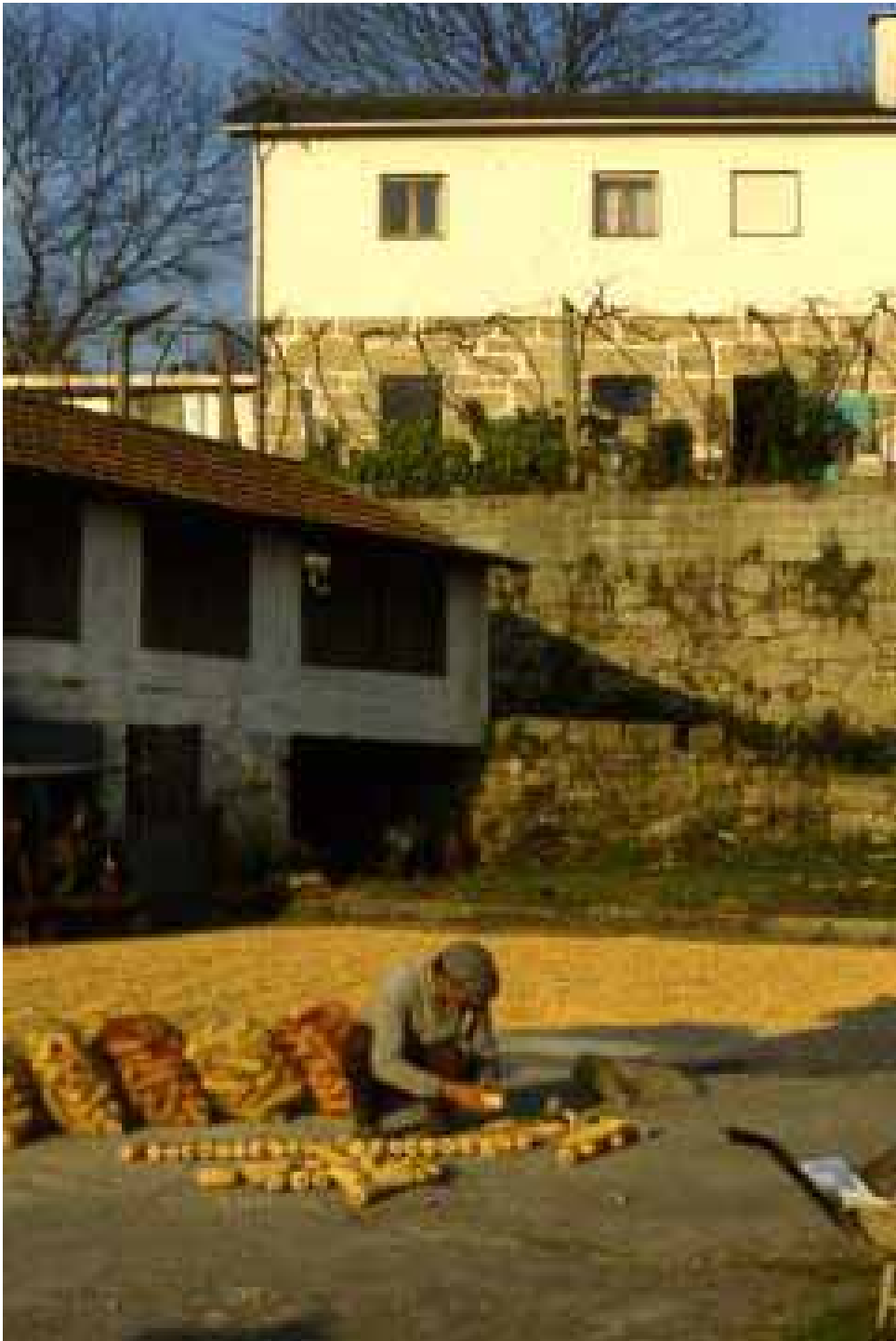

## **‘Pigarro’**

- Selection at the storing facilities

# 'Pigarro'

After the field selection  
Selection at store "Seleccção da Eira" will  
begin  
On the left side ears from prolific plants





# 'Fandango' selection Synthetic

# 'Fandango' selection

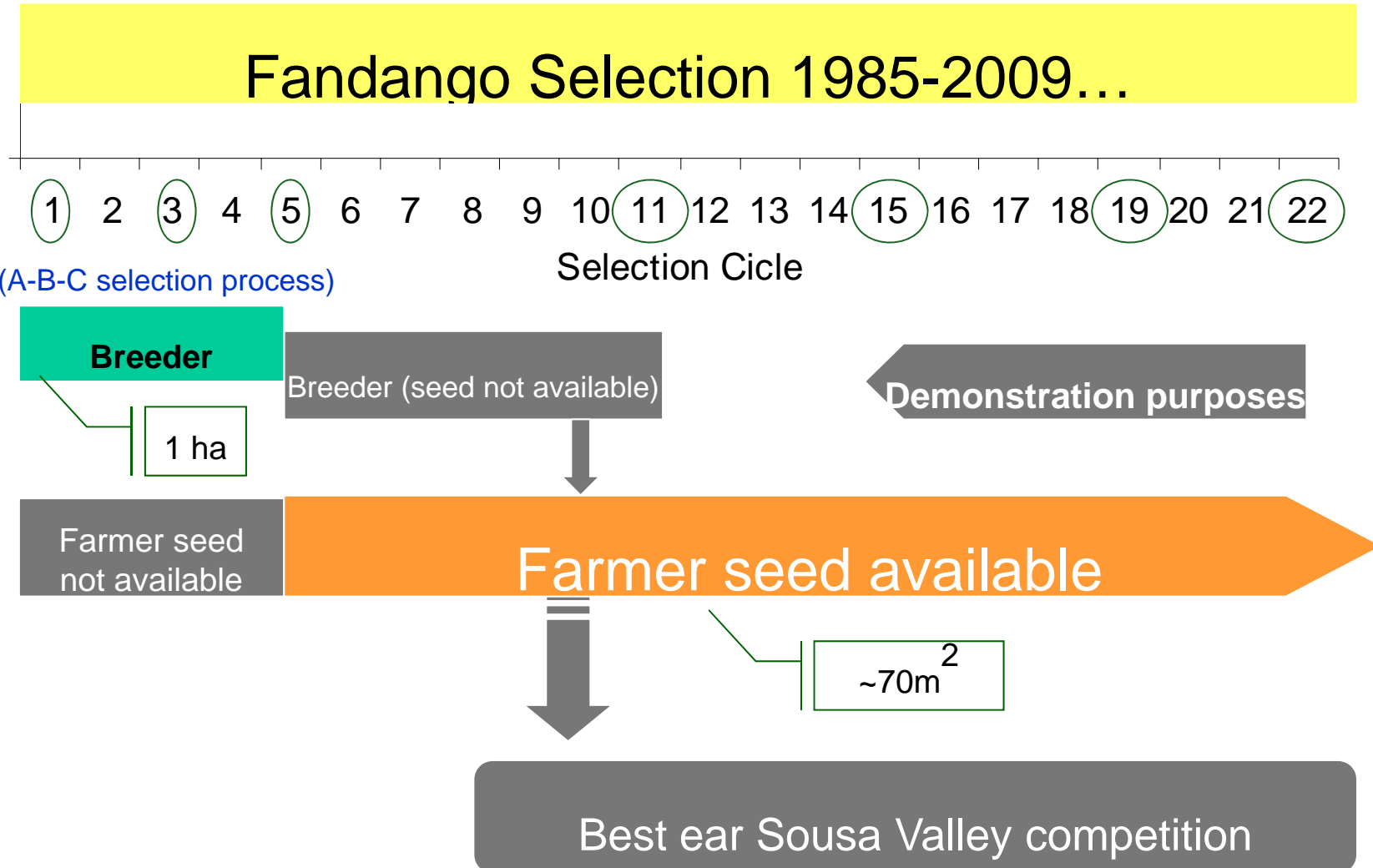

Fandango

Hybrid





# Evaluation trials

## Material and Methods

Phenotypic  
Evaluation

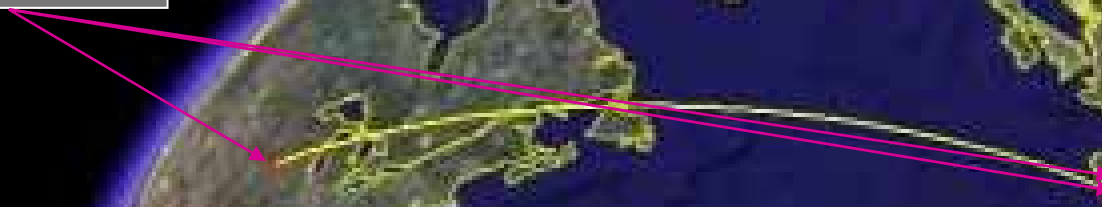

Google Earth interface elements:

- Search bar:
- Altitude: 8,893,77
- Map type:  Streets  Terrain  Hybrid  3D
- Link button

© 2008 Europa Technologies  
Image © 2008 TerraMetrics

Google™

24°30'31.44" N 87°04'17.95" W

Plano: 100%

Altitude do ponto de vista: 12108.34 m

## Material and Methods (Trials)

Four locations in Iowa during 2005



## Three locations in Portugal (2005-2008)

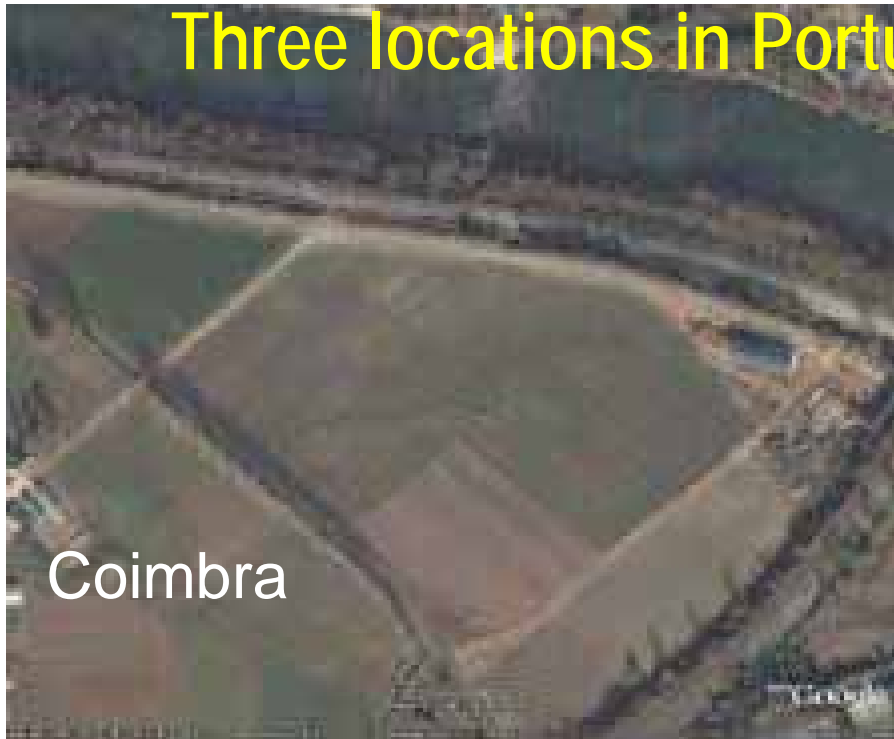

### Excluded

#### Fandango

- all locations in 2006

#### Pigarro

- 2008 for Lousada
- 2006 for Montemor

# Material and Methods

## ■ 'Pigarro' - 10 entries

- ◆ Massal sel. C0-84, C4-88, C6-90, C9-93, C12-96, C15-99 and C20-04
- ◆ Recurrent sel. C1(S2)89, C2(S2)94, C3(S2)98

## ■ 'Fandango' - 5-7 entries

- ◆ Mass. Selection Breeder:
  - ◆ C1—86, C3—88 (except 2007), C5—90
- ◆ Mass. Selection Farmer:
  - ◆ C11—96, C15-00, C19-04, C22-07 (only 2008)

## ■ 3 Replications

## ■ Plots

- ◆ Portugal **9.6 m<sup>2</sup>** (2 rows x 7.00 m length x 0.75 m between rows);
- ◆ Iowa **8.31 m<sup>2</sup>** (2 rows 5.47 m length 0,76 m between rows)
- ◆ Density ~50 000



## Material and Methods Traits

|                            |                            |                            |
|----------------------------|----------------------------|----------------------------|
|                            | Plant height, m (x10) ‡    | Ear%Moisture               |
|                            | Ear height, m (x10) ‡      | Kernel dept, cm (x10) ‡    |
|                            | Ear Lenght, cm             | Kernel number, n°          |
| Yield, mg ha-1             | Ear Diameter 1, cm (x10) ‡ | Thousand kernel weight, g  |
| Moisture %                 | Ear Diameter 3, cm (x10) ‡ | Kernel per row, n°         |
| Days-to-silk, n° †         | Ear Diameter 2, cm (x10) ‡ | Cob diameter 1, cm (x10) ‡ |
| Days-to-silk, n° † end     | Ear Diameter 4, cm (x10) ‡ | Cob diameter 3, cm (x10) ‡ |
| Days-to-anthesis, n° †     | Kernel-row number 1, n°    | Cob diameter 2, cm (x10) ‡ |
| Days-to-anthesis, n° † end | Kernel-row number 2, n°    | Cob diameter 4, cm (x10) ‡ |
| OI                         | Fasciation                 | Medula 1, cm (x10) ‡       |
| H                          | D/I %de Ind                | Medula 2, cm (x10) ‡       |
| U                          | Convulsion                 | Raquis 1, cm (x10) ‡       |
| N                          | F/D                        | Raquis 2, cm (x10) ‡       |
| T                          | Ear weight, g              |                            |
| E                          | Kernel weight, g           |                            |
| S                          | Cob weight, g (x10) ‡      |                            |
| R                          | CW/EW                      |                            |

# Material and Methods (Data analyses)

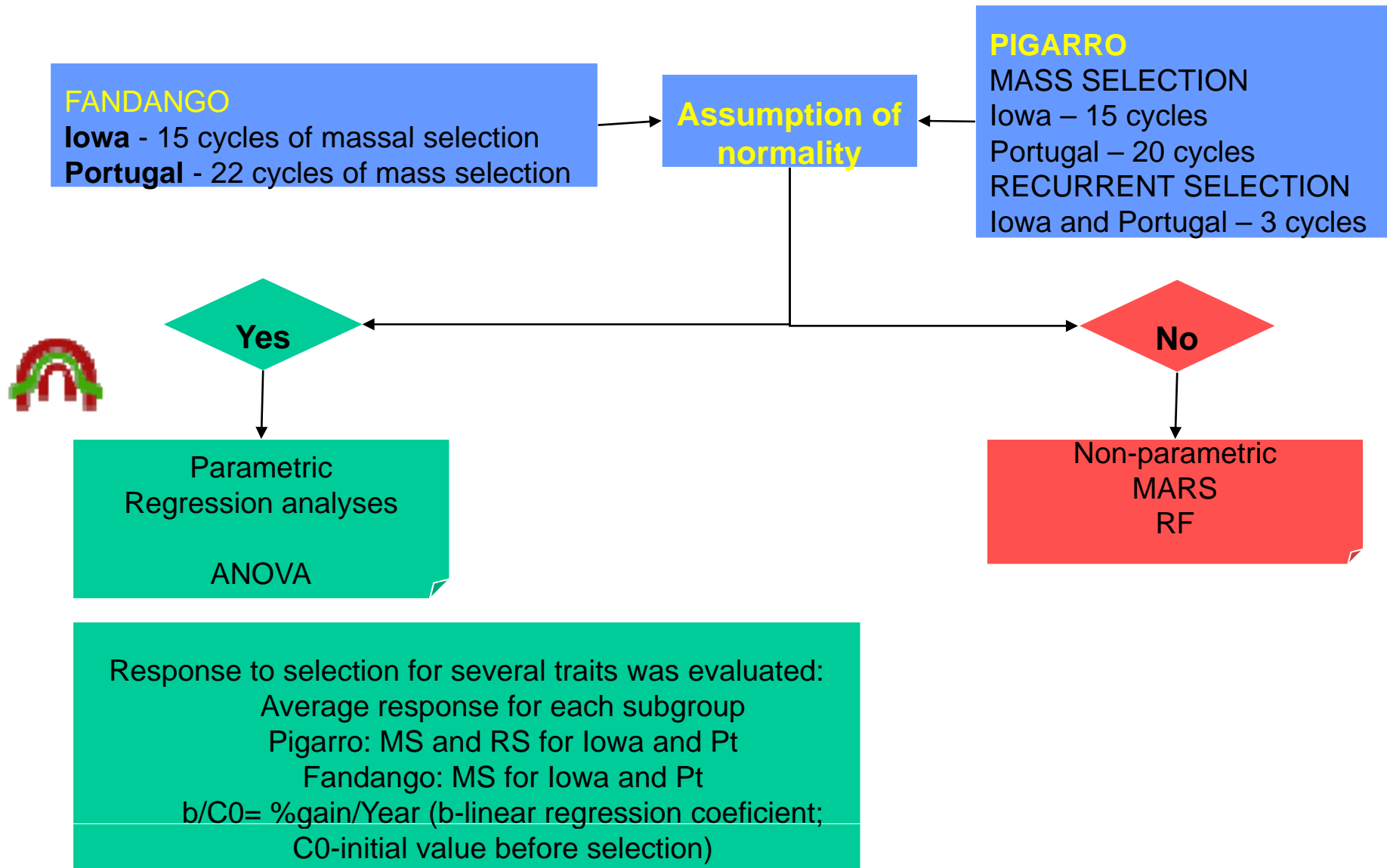

## Material and Methods

- A second analysis was performed in order to get insights on the causes that explain the yield. We have used three methods for analysis:
  - ◆ MARS
  - ◆ Classification and Regression Trees (CART)
  - ◆ Random Forests (RF).
- The reason to use three methods instead of just one is to get advantage of their complementary characteristics in order to better understand what influences the yield in both populations



# Results

Evaluation trials  
FANDANGO  
Results

# Fandango Lousada

| Traits                     | Mass selection |   |      |    |                |         |       |
|----------------------------|----------------|---|------|----|----------------|---------|-------|
|                            | Pt - Lousada   |   |      |    |                |         |       |
|                            | b              |   |      | Ĉ0 | R <sup>2</sup> | %C/Y    |       |
| Yield, Mg ha <sup>-1</sup> | -0,03          | ± | 0,03 |    | 8,76           | 0,16644 | -8,52 |
| Moisture %                 | 0,20           | ± | 0,04 | ** | 31,62          | 0,80509 | 0,62  |
| Plant height, cm           | 1,77           | ± | 0,49 | *  | 283,18         | 0,52696 | 0,63  |
| Ear height, cm             | 2,13           | ± | 0,21 | ** | 150,14         | 0,95344 | 1,42  |
| Ear Length, cm             | -0,11          | ± | 0,03 | ** | 22,43          | 0,78318 | -0,51 |
| Ear Diameter 3, cm         | 0,04           | ± | 0,01 | ** | 4,54           | 0,88572 | 0,84  |
| Ear Diameter 2, cm         | 0,03           | ± | 0,00 | ** | 4,93           | 0,94419 | 0,52  |
| Ear Diameter 4, cm         | 0,02           | ± | 0,00 | ** | 4,51           | 0,87326 | 0,55  |
| Fasciation                 | 0,06           | ± | 0,01 | ** | 1,31           | 0,78797 | 4,66  |
| F/D                        | 0,00           | ± | 0,01 |    | 6,35           | 0,00115 | -0,02 |
| Ear weight, g              | -0,36          | ± | 0,69 |    | 275,32         | 0,05251 | -0,13 |
| Kernel weight, g           | -0,33          | ± | 0,61 |    | 231,90         | 0,05502 | -0,14 |
| Cob/Ear weight             | 0,00           | ± | 0,00 |    | 0,16           | 0,00105 | 0,01  |
| Kernel dept, cm            | 0,00           | ± | 0,00 |    | 1,21           | 0,55649 | 0,17  |
| Kernel number, n°          | 4,56           | ± | 1,67 | *  | 583,15         | 0,59702 | 0,78  |
| Thousand kernel weight, g  | -2,99          | ± | 0,41 | ** | 397,08         | 0,91423 | -0,75 |
| Kernel per row, n°         | -0,19          | ± | 0,04 | ** | 41,57          | 0,78674 | -0,45 |
| Cob diameter 1, cm         | 0,03           | ± | 0,00 | ** | 3,33           | 0,95888 | 0,91  |
| Cob diameter 3, cm         | 0,03           | ± | 0,00 | ** | 2,68           | 0,90854 | 1,13  |
| Cob diameter 2, cm         | 0,02           | ± | 0,00 | ** | 3,15           | 0,97984 | 0,52  |
| Cob diameter 4, cm         | 0,01           | ± | 0,00 | ** | 2,66           | 0,83498 | 0,55  |
| Medulla 1, cm              | 0,03           | ± | 0,00 | ** | 1,22           | 0,97009 | 2,49  |
| Medulla 2, cm              | 0,02           | ± | 0,00 | ** | 1,02           | 0,82594 | 1,64  |
| Raquis 1, cm               | 0,03           | ± | 0,00 | ** | 2,38           | 0,98608 | 1,18  |
| Raquis 2, cm               | 0,01           | ± | 0,00 | ** | 2,15           | 0,77849 | 0,63  |

# Fandango - Lousada

|                         | K-S Lilliefors |           | MARS - MULTIVARIATE ADAPTIVE REGRESSION SPLINES |   |
|-------------------------|----------------|-----------|---|---|
|                         | statistic      | p.value   | R <sup>2</sup>                                  | equation: Explaining each variable along cycles                     |
| Uniformity              | 0,2466         | 0,0000 ** | 0,0000  | 5,1296300   |
| aNgle                   | 0,3919         | 0,0000 ** | 0,1137  | 4,87533093-0,09241877*max{0,(Cycle-15)}                             |
| Tassel                  | 0,3097         | 0,0000 ** | 0,1726  | 6,10919406+0.07165617*max{0,(Cycle-11)}                             |
| Ear placement           | 0,3472         | 0,0000 ** | 0,0000  | 5,0556  |
| Root lodging %          | 0,2933         | 0,0000 ** | 0,0000  | 0,03547963  |
| Stalk lodging %         | 0,2978         | 0,0000 ** | 0,0000  | 0,1070907   |
| Ear Diameter 1, cm      | 0,1314         | 0,0209 *  | 0,0000  | 41178227+0,05377996*max{0,(Cycle-11)}-0,02942301*max{0,(11-Cycle) } |
| Kernel-row number 1, n° | 0,1346         | 0,0160 *  | 0,0000  | 5,4113404+0,3027652*max{0,(Cycle-5)}                                |
| Kernel-row number 2, n° | 0,1383         | 0,0117 *  | 0,0000  | 5,3078161+0,2852895*max{0,(Cycle-5)}                                |
| D/l                     | 0,2931         | 0,0000 ** | 0,0000  | 1,075   |
| Convulsion              | 0,1253         | 0,0340 *  | 0,3429  | 1,53684231+0,05397529*max{0,(Cycle-11)}                             |
| Kernel colour           | 0,1717         | 0,0004 ** | 0,0000  | 4,160185  |
| Ear Moisture %          | 0,1378         | 0,0122 *  | 0,1712  | 315,988426-2,230787*max{0,(15-Cycle)}                               |
| <i>Ustilago maydis</i>  | 0,3086         | 0,0000 ** | 0,0000  | 0,6852  |
| <i>Puccinia spp.</i>    | 0,2801         | 0,0000 ** | 0,0000  | 2,16667   |

# Fasciation

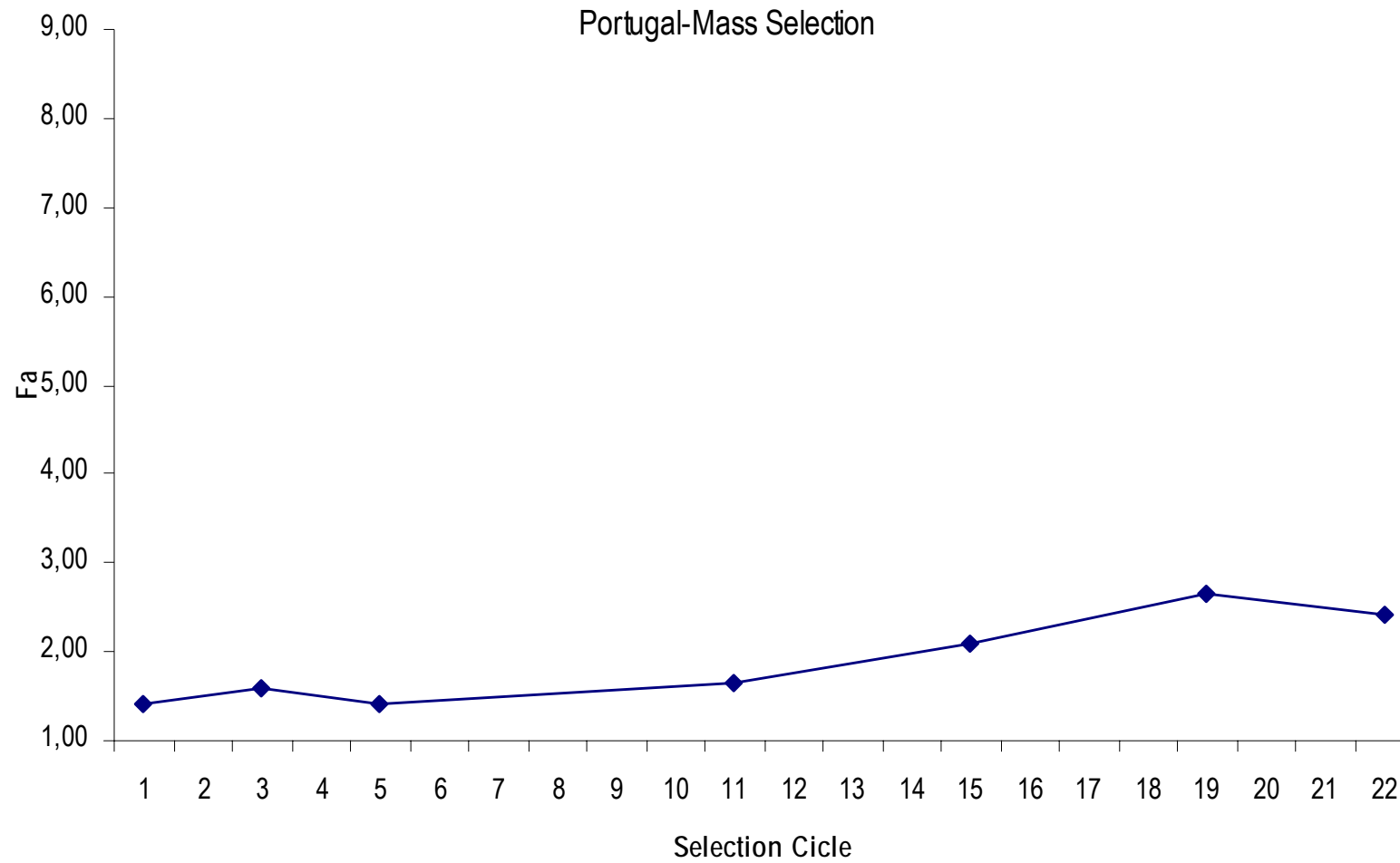

## Results – Fandango, Yield

Random Forests - % Var explained: 46,33%

rf2

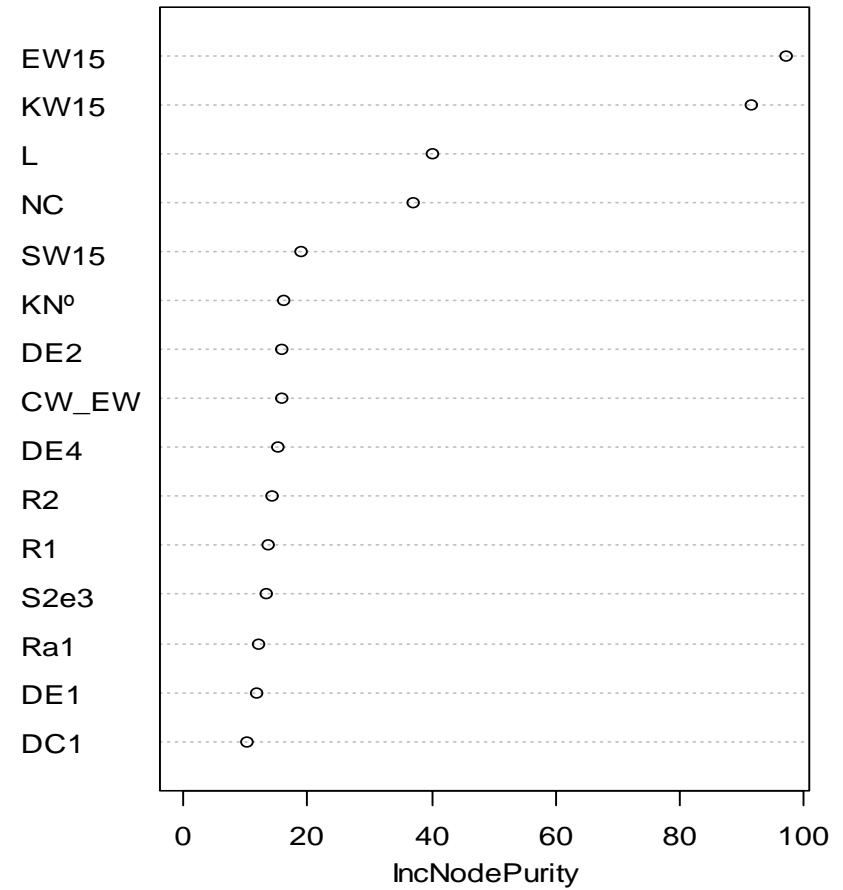
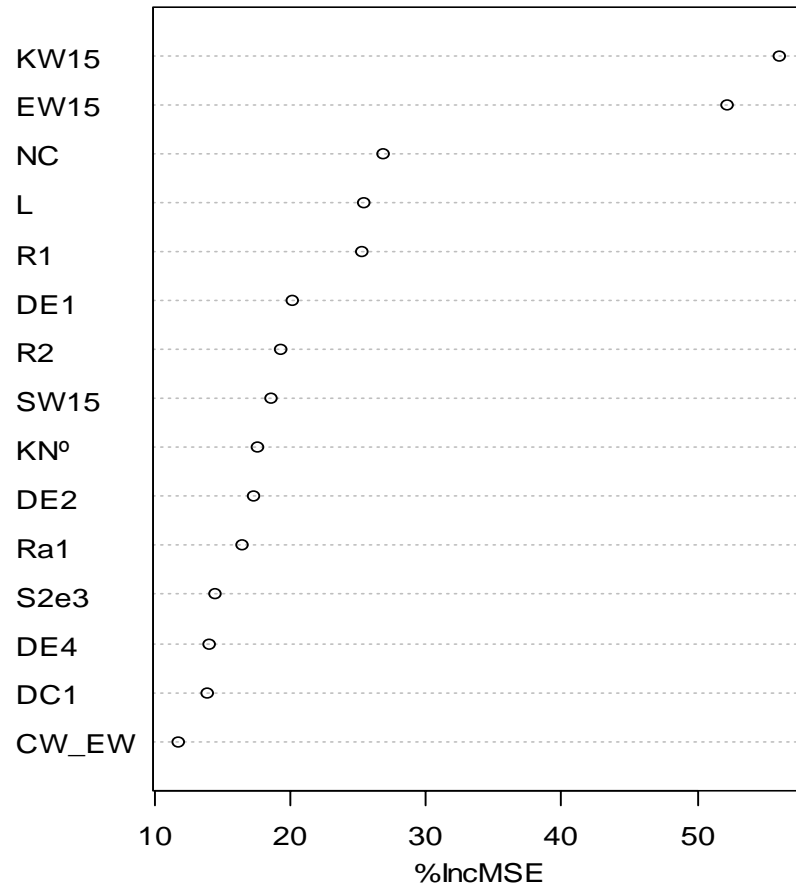

# Classification and Regression Trees (CART)

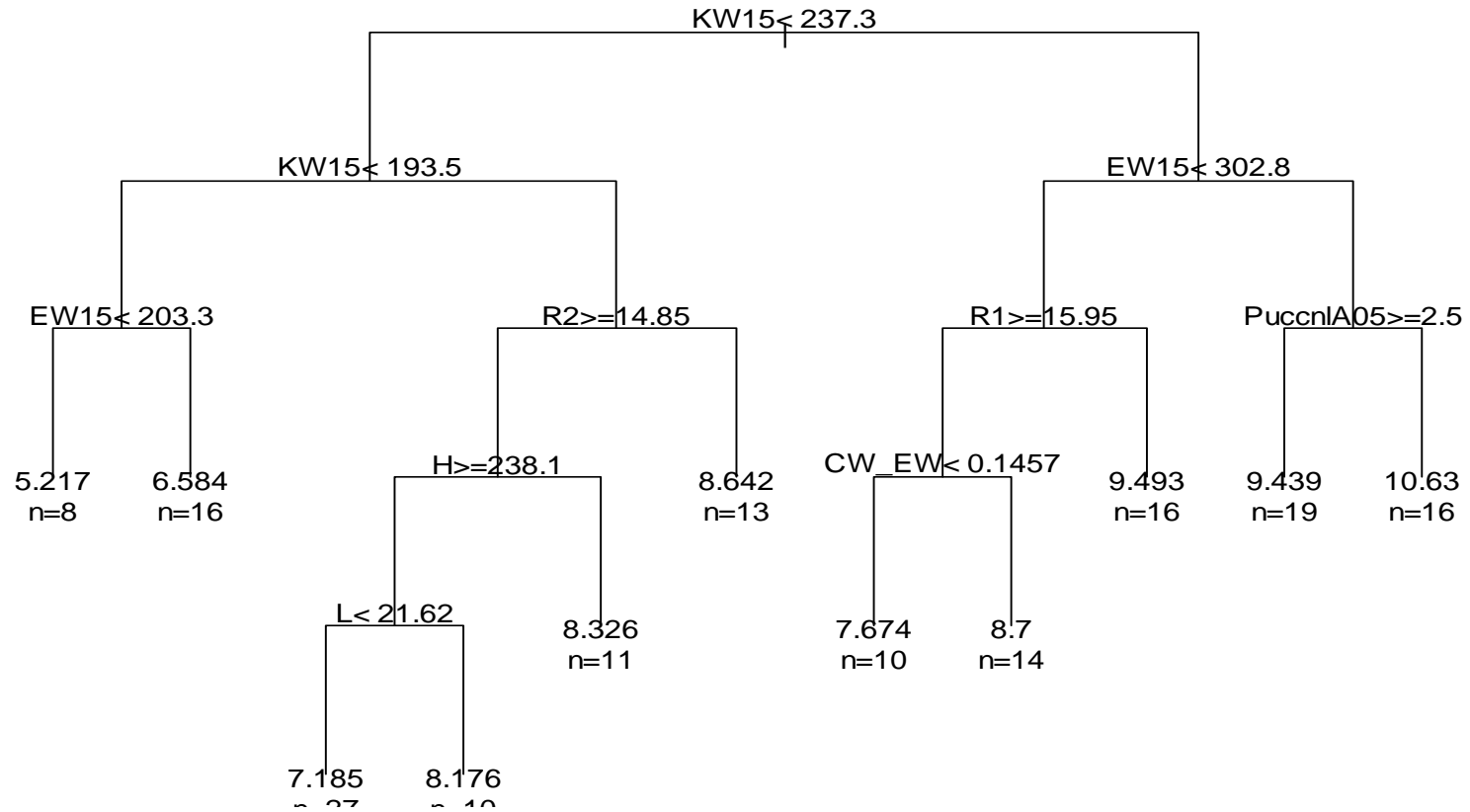

# MARS

MARS

R<sup>2</sup>: 66,47%

Yield15 = 7,646942

+0,02907435\*max{0,(EW15-224,725)}

-0,03713933\*max{0,(224,725-EW15)}

+0,09444964\*max{0,(R1-17,7)}

+0,39985435\*max{0,(17,7-R1)}

-9,25877315\*max{0,(CC-1,85)}

-0,90064337\*max{0,(1,85-CC)}

-0,08650634\*max{0,(MOIST-22,8)}

-0.26639750\*max{0,(22,8-MOIST)}

+0,17794504\*max{0,(H-21,25)}

-0,09901524\*max{0,(21,25-H)}

0,60245241\*max{0,(U-6)}



# Conclusions



## Conclusions - Pigarro

## Conclusions - Pigarro

- Selection for bigger ears (larger and wider ears) reveal that mass and recurrent selection were effective for some traits modification.
- After 20 cycles of mass selection:
  - ◆ **Ear length** decreased and simultaneously, **ear, cob medulla and raquis diameters, kernel and cob weight and fasciation** significantly increased.
  - ◆ This selection also lead to increase of days to silk and anthesis.
- After 3 cycles of recurrent selection
  - ◆ Convulsion decreased significantly while row number decrease so as fasciation

## ***Pigarro - Molecular***

- Evaluation of Pigarro's genetic diversity evolution through 20 years of mass selection. 16 SSR, 3 selection cycles (1984, 1993, 2004)

**no effective loss of genetic diversity has occurred during the selective adaptation to the farmer's needs and the regional growing conditions.**

**96.26% of variation was attributable to within-selection cycles diversity indicating that a great proportion of the genetic diversity is maintained in each selection cycle**

- The evaluation of the Pigarro's genetic diversity evolution on the breeder's selection will come up soon.

VAZ PATTO, M.C.; MOREIRA, P.M.; ALMEIDA, N.; SATOVIC, Z. & PÊGO, S. (2007) Genetic diversity evolution through participatory maize breeding in Portugal. *Euphytica*. DOI 10.1007/s10681-007-9481-8





## Conclusions - Fandango

# Conclusions - Fandango

- During the selection process there were two phases:
  - 1) The breeder phase from cycle 1 to cycle 5 and
  - 2) The farmer phase, after cycle 5.
- Both have different goals, breeder for yield maximization and farmer for big ear size maximization.
- The results from response to mass selection in *Portugal* revealed that **ear length** significantly decreased and simultaneously **plant and ear height, ear diameter, kernel row number and fasciation** significantly increased so as **convulsion** (but for breeder cycles these traits were maintained). This selection also led to significant increases of days-to-silk and anthesis. Identical outcomes were observed in long-term divergent selection for ear length in maize (Hallauer, 1992)

- According with MARS ( $R^2=8,9\%$ ) the breeder maintained the grain moisture during breeding process (cycle 5), but farmer did contribute to grain moisture increase, at Lousada ( $R^2=80,5\%$ ). This tendency did also occur to days-to-silk and to days-to-anthesis
- ‘Fandango’ is *not adapted to high densities*, during selection plant and ear height significantly increase, which could mean less area available, *i.e.*, competition in trials was more severe to advanced cycles and some plants did not produce ears. Probably for this reason significant decrease in yield was observed at lowa locations.



## General conclusions

## General conclusions

- The lack of significant progress in yield for both 'Pigarro' and 'Fandango' (after C5) so as methodologies can be explained by:
  - ◆ Low selection intensity due to the exclusion of stalk lodged plants in the basic units of selection that could reduce the intensity of selection for yield

## General conclusions

- The fasciation evaluation, indicates that **farmer explore fasciation for increase diameter and row number**. This fact is specially significantly interesting at Lousada for:
  - ◆ Pigarro ( $R^2=88,7$ ) with **3,32%** of gain per cycle/year and
  - ◆ Fandango ( $R^2=78.8$ ) with **4,66%** of gain per cycle/year

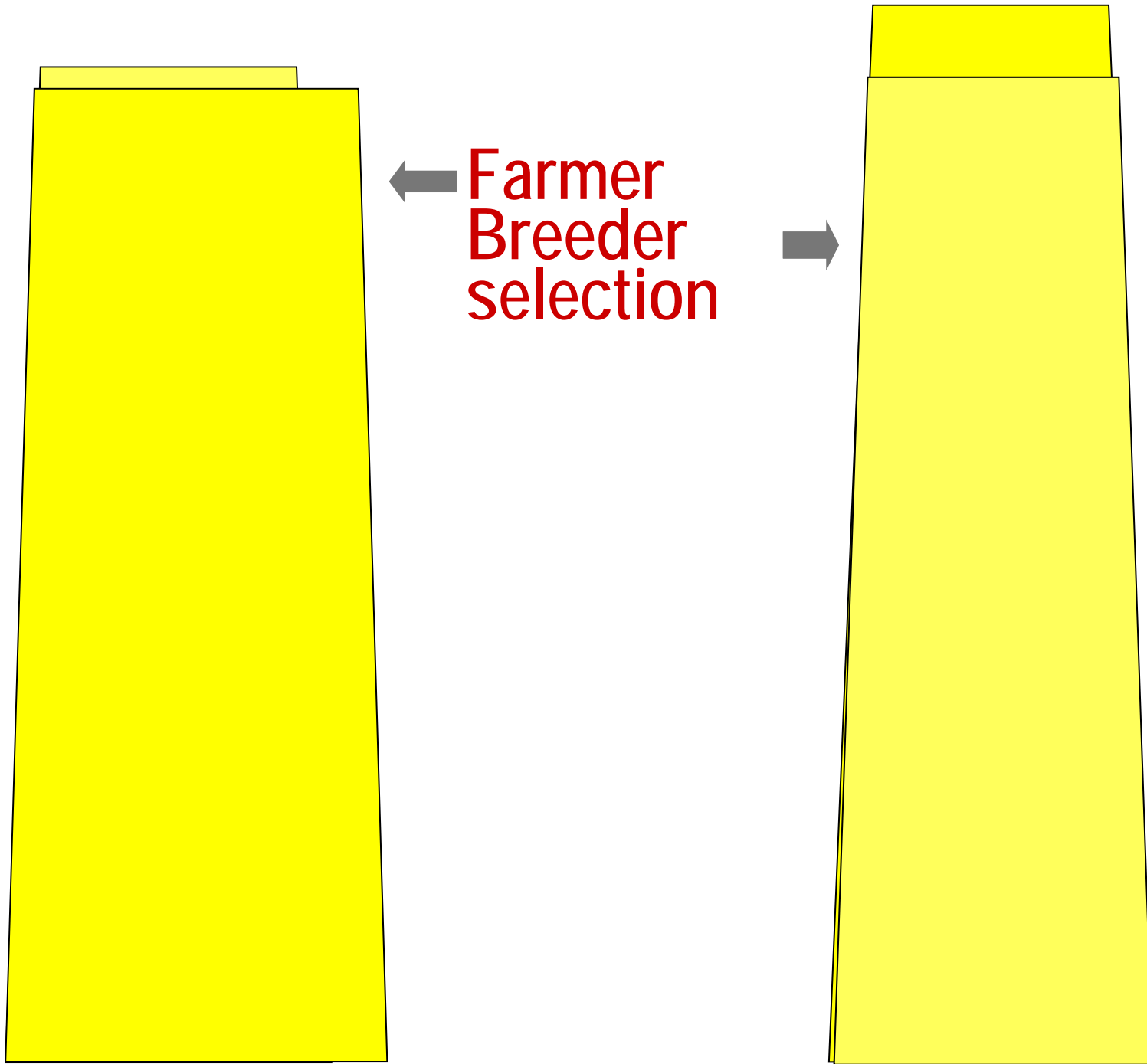

Farmer  
Breeder  
selection

# Yield - mass selection for 'Pigarro' and for 'Fandango'

- Analysis using RF, CART and MARS reveal that Kernel weight and Ear weight were the most distinct traits for all methods in both populations
- but row numbers number of kernels per row, Ear length and ear diameter were also some of the important traits that influence yield.
- For recurrent selection, Plant and ear height, flowering date and kernel number

Mr Meireles as winner of Sousa Valey Best Ear contest(14 years)



**Pedagogic tool**

**2) Germplasm “tracker”**

**3) Germplasm “disseminator”**

**4) Social aspects:**



Future Perspectives

# Future

- New experiments: plant densities trials with maize *per se* or in polycrop systems, fertilization trials
- Contribution to the elucidation of the genetic basis of the fasciation trait, typical of the 'Pigarro' and 'Fandango' germplasm.
- Continue to study the maize quality for Maize bread "Broa"
- Provide to farmers alternative germplasm for marginal areas and for nich market products
- Molecular data
  - ◆ Clarify the evolution of NUTICA and Fandango



**Pre-breeding, breeding, PPB**

Pedro Mendes Moreira  
ESAC

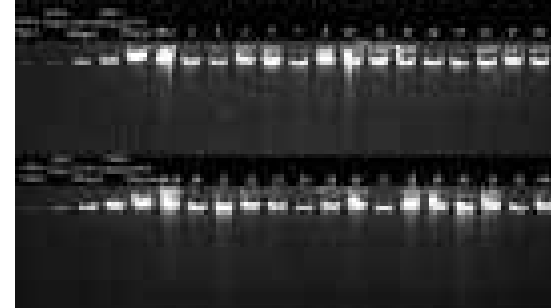

**Molecular**  
Carlota Vaz Patto  
ITQB

FCT (PTDC/AGR-ALI/099285/2008)  
«**Exploiting antioxidants, flavours and  
aromas diversity on 'broa' bread maize  
breeding** »



**Winter nursery**  
João Cândido Souza  
UFLA

**Food  
quality**  
Carla Brites  
EAN





Strategies for Organic and Low-input  
Integrated Breeding and Management

Solibam





# Acknowledgements

Helping to keep this long legacy...

- ECPGR
- To Mr Francisco Meireles
- To Eugénio Andrade
- Municipality of Lousada for long term commitment on VASO Project
- FCT (PTDC/AGR-ALI/099285/2008)
- FCT (PTDC/AGR-AAM/70845/2006)
- SFRH/BD/22188/2005
- SFRH/PROTEC/50365/2009
- COST 866 Green Care in Agriculture
- To my students
- To Daniela, Lucas and Sara